



by Honeywell

E3 Series®

Broadband

Description

The E3 Series® Broadband System includes the NetSOLO® Broadband System. Like the NetSOLO® Broadband System, the E3 Series® Broadband is of modular design and allows a wide range of configurations from two basic assemblies. These assemblies form an integrated, distributed fire alarm system that includes audio evacuation and fire command capability. The network communication transmits all fire alarm, audio evacuation, voice paging, and fire fighter communications.

E3 Series Broadband is a revolutionary advance in fire detection and emergency voice evacuation system design. E3™ Series Broadband employs proven technology and expands it to accomplish emergency multi-channel voice evacuation, two-way fire fighter communications, and building control applications, all over a single pair of wires or fiber-optic cable.

It is a true peer-to-peer, token ring passing, networked system capable of supporting up to sixty-four (64), individual nodes. All system status, control-by-event sequences, audio voice paging, and fire fighter telephone signals are sent between nodes over a single pair of wires or fiber optic cable.

Each E3 Series Broadband node can be spaced along the network a maximum distance of 3,000 feet (914.4 m) over an unshielded twisted-pair of wires or fiber-optic cable with up to 8dB loss. Built-in isolation at each node permits Style 4, 6, and 7 network configurations.

E3 Series Broadband is simple to configure for any project requirement. A complete E3 Series Broadband application can be assembled from just three types of nodes; the 7100 NetSOLO, the INCC Command Center, and the INX Transponder.

E3 Series Broadband is capable of the most sophisticated sequences of operations.

E3 Series® and NetSOLO® are registered trademarks of Honeywell International Inc. UL® is a registered trademark of Underwriters Laboratories Inc.

Intelligent, Networked, Multi-Channel Fire Alarm Control and Emergency Voice Evacuation System



E3 Series Broadband

Features

- Listed under UL® Standard 864, 9th Edition
- UL Listed for smoke control (dedicated and non-dedicated) when properly configured
- All communication signals and control-by-event sequences over a single pair of twisted, unshielded wires or fiber-optic cable
- Distributed architecture, including Style 7 wiring configurations, allow system components to continue normal operation with no loss of function during single line fault conditions
- Integrates INX transponders and INCC command centers to create a complete audio evacuation system with up to sixty-four (64) nodes
- Redundant command centers with microphone and fire fighter's handset easily configured by adding INCCs
- State-of-the-art digital signal processor (DSP) technology for efficient audio compression and filtering
- Up to 150 watts of audio power from three (3), AM-50 amplifiers with an additional 50 watts of standby power in each intelligent network transponder (INX) cabinet

An ISO 9000-2000 Company



GAMEWELL-FCI

12 Clintonville Road, Northford, CT 06472-1610 USA • Tel: (203) 484-7161 • Fax: (203) 484-7118

Specifications are for information only, are not intended for installation purposes, and are subject to change without notice. No responsibility is assumed by Gamewell-FCI for their use.

©2008 by Honeywell International Inc. All rights reserved.

www.gamewell-fci.com

9020-0613 Rev. D1 page 1 of 5

Description (Continued)

The Field Configuration Program (FCP) is based on Boolean logic statements providing AND, OR, NOT, and XOR logic operators. These can be combined to produce additional Boolean operators such as NAND, NOR, XNOR, etc. system silence, etc. The E3 Series Broadband is software-programmable for multi-channel digital audio applications. It is ideal for a wide range of complex system applications including high-rise or campus installations. An array of cabinets allows for neat, compact, attractive installations.

A comprehensive set of timing functions can also be attached to any input/output logic statement for staggered reset of fan control relays, time-delayed alarm activation, automatic.

The E3 is a microprocessor-based fire alarm control panel that uses an ILI-MB-E3 Intelligent Loop Module with two (2) signaling line circuits and two (2) notification appliance circuits. When transmitting to remote locations, the optional RPT-E3 provides the ILI-MB-E3 with signal boosting and transient protection, as well as connectivity for both wire and fiber-optic cables. Options also include an integral Digital Alarm Communicator Transmitter (DACT) supporting most popular reporting formats.

The Intelligent Network Command Center (INCC) serves as the point of interface between an operator and the system's audio evacuation, fire fighter intercom, and building network. The INCC occupies a single address on the E3 Series Broadband network. A typical INCC assembly consists of an Intelligent Network Interface-Voice Gateway (INI-VGC-FO or INI-VGC-UTP) module (fiber-optic or unshielded twisted-pair), or INI-VGC-UTP (unshielded twisted-pair only), one or more Addressable Switch Modules (ASM-16), optional Network Graphic Annunciator (NGA) and remote 48 LED driver module (ANU-48).

Options include a paging microphone and a fire fighter's handset connecting to the INI-VGC-FO or INI-VGC-UTP. Each INI-VGC can support up to sixteen (16), ASM-16 modules. Each ASM-16 has sixteen (16), push-button switches for a maximum capacity of 256 switches per INI-VGC command center. Each switch has three (3), associated LEDs, colored green, yellow, and red. These switches and their LEDs are fully programmable to serve any system function desired. They can control audio speaker circuits, notification appliance circuits, addressable relay outputs, fire fighter phone control circuits, or any special application that might be required.

Multiple INCCs can be configured into the E3 Series Broadband network to serve as a completely independent command center for their local area or as remote command centers mimicking, in part or in whole, the function of a main command center.

The Intelligent Network Transponder (INX) acts as a network audio transponder for the E3 Series Broadband Network. The INX transponder serves as the point of distribution for the system's audio and fire fighter telephone circuits and occupies a single node on the E3 Series Broadband network.

A typical INX assembly consists of an ILI-MB-E3 or ILI-S-E3, an Intelligent Network Interface-Voice Gateway (INI-VGX) module, a PM-9 power supply, and up to four (4), AM-50 amplifiers. The INX transponder occupies a single address on the network and provides termination points for the network connection using either a pair of unshielded twisted-pair wire or fiber-optic cable.

The INI-VGX uses advanced Digital Signal Processing (DSP) technology for audio compression and filtering allowing E3 Series Broadband to produce the clearest audio possible while conserving network bandwidth for instantaneous response. Background noise is automatically filtered during voice paging and fire fighter communications increasing audibility and eliminating the need for push-to-talk devices.

The INI-VGX can accommodate up to sixteen (16), different messages with a total combined duration of three minutes. Each message can be field installed via a laptop computer and can be in the form of a voice message or an evacuation tone.

The INI-VGX also provides a fire fighter phone riser and an addressable signaling line circuit connecting to multiple phone jacks or warden stations through as many as sixteen (16), AOM-TELF modules. In addition, the INI-VGX SLC can support up to thirty-two (32), speaker circuits using the AOM-MUXF for dual channel applications.

The INX can contain four (4), 50 watt, 25 V_{RMS} AM-50 audio amplifiers, each with two (2), separate speaker circuits that can be wired Style Y (Class B) or Style Z (Class A). Each amplifier can produce its own tone or message independently of other system amplifiers. Thus, an INX transponder can produce three (3), audio channels simultaneously. Each INX transponder can support four (4), AM-50s as main amplifiers with one (1), AM-50 as a fail-safe backup amplifier.

The INX transponder receives its power from a PM-9, 9 ampere, filtered, switching power supply providing twenty-four (24), VDC nominal operating voltage. The PM-9 has an integral standby battery charger capable of recharging up to fifty-five (55), A/H batteries. The E3-BB-BC/INX cabinet can house up to 18 A/H sized batteries.

GAMEWELL-FCI

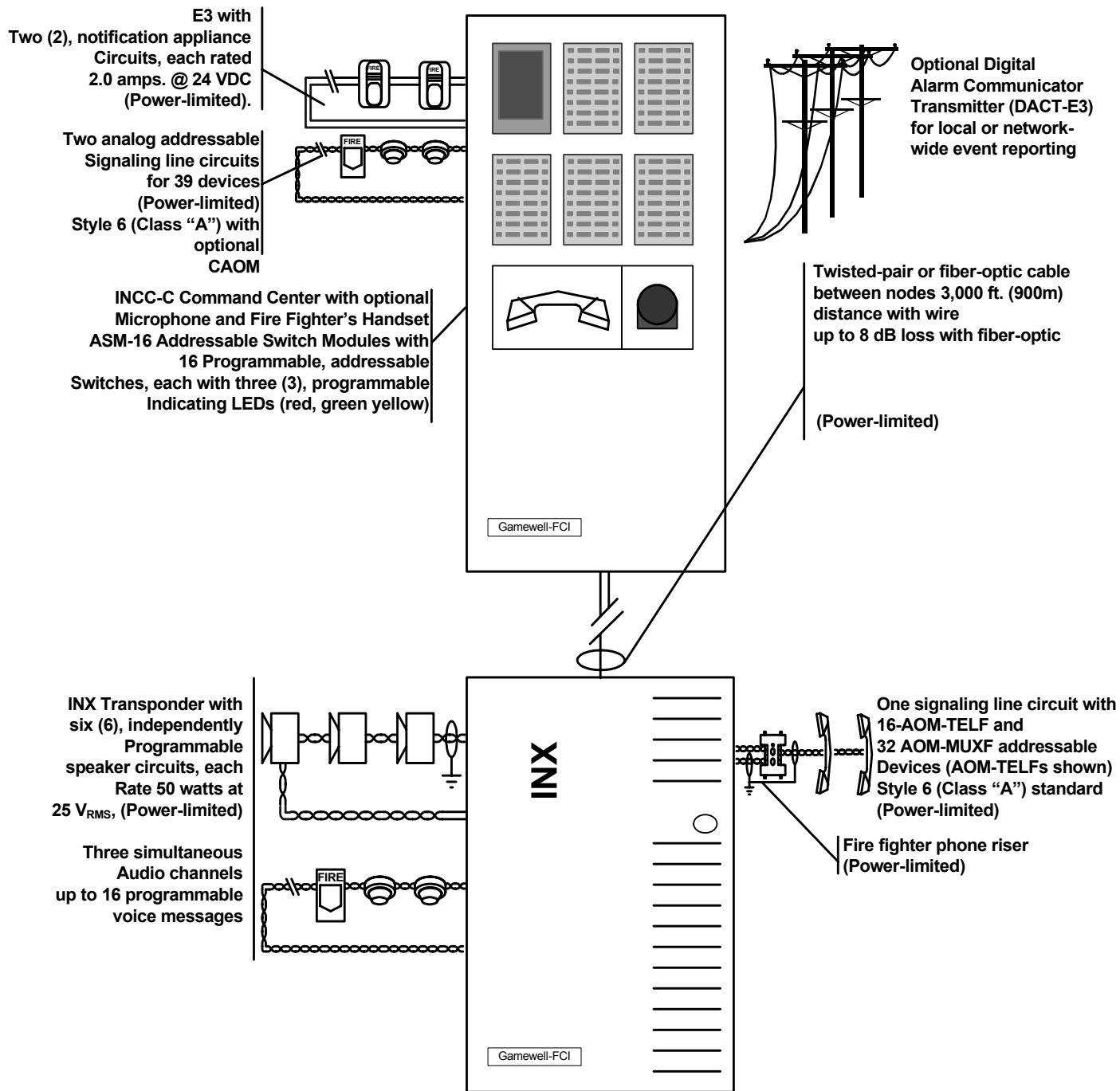

Figure 1

GAMEWELL-FCI

12 Clintonville Road, Northford, CT 06472-1610 USA • Tel: (203) 484-7161 • Fax: (203) 484-7118

www.gamelwell-fci.com

9020-0613 Rev. D1 page 3 of 5

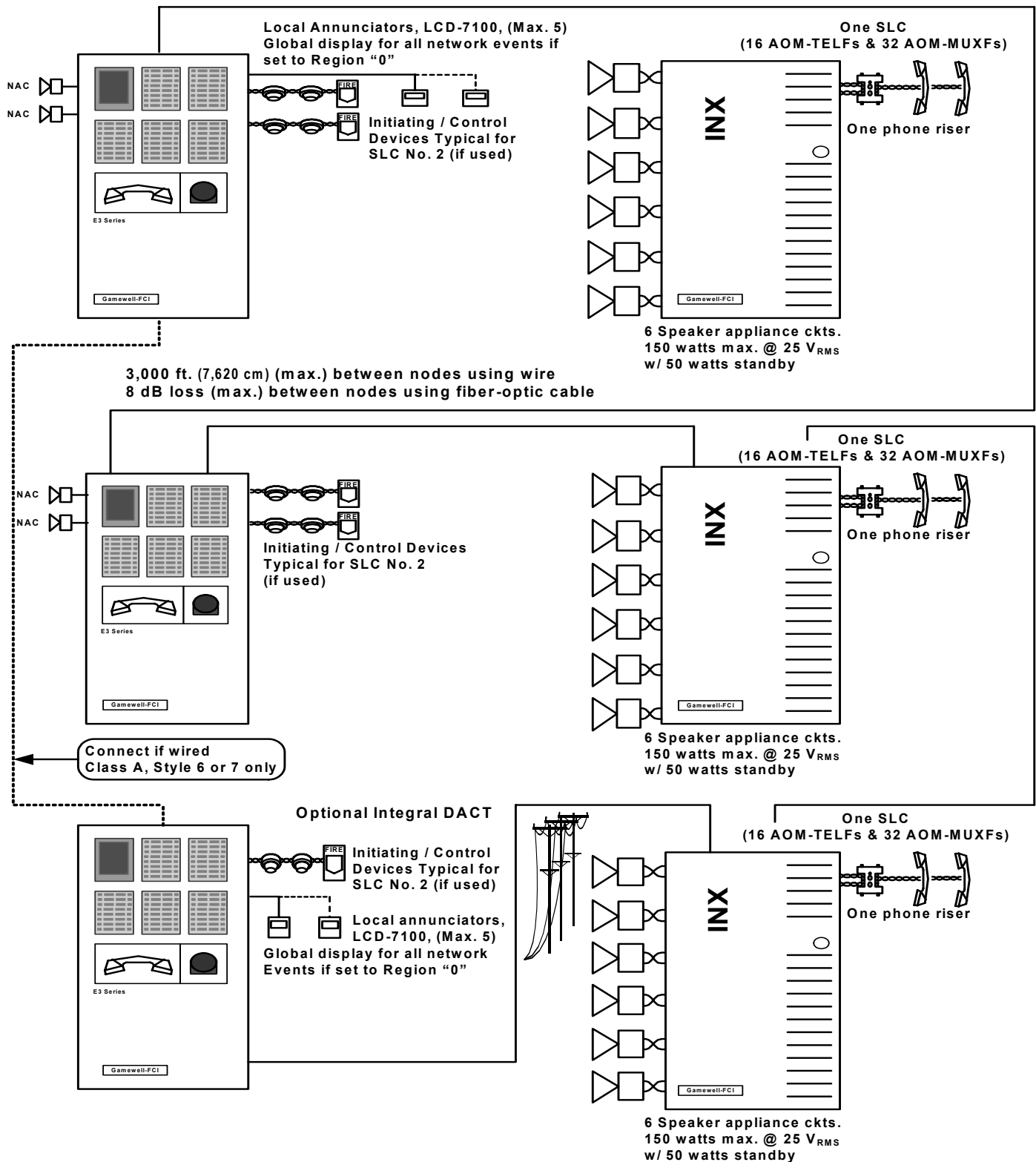

Figure 2

Specifications

Detailed product specifications may be found in:

9020-0542	INCC Intelligent Network Command Center Datasheet
9020-0637	E3 Series Control Panel Datasheet
9020-0541	INX Intelligent Network Transponder Datasheet

Ordering Information

E3 Control

Part Number	Description
ILI-MB-E3	Intelligent Loop Interface-Main Board
LCD-E3	LCD Keypad Display
PM-9	Power Supply
RPT-E3	Network Repeater
DACT-E3	Digital Alarm Communicator Transmitter
LCD-7100 (Optional)	Remote Serial LCD Display

INCC Intelligent Network Command Center

Part Number	Description
INI-VGC	Command Center Voice Gateway
INI-VGC-UTP	Voice Gateway for unshielded twisted-pair wire only
ASM-16	Programmable Switch Module (occupies single slot of inner door)
NGA	Network Graphic Annunciator
ANU-48	Remote LED Driver
INCC-IDT	Inner door w/one double slot for INCC-TEL fire fighter handset and 4 single slots

Ordering Information (Continued)

INCC Intelligent Network Command Center (Continued)

Part Number	Description
INCC-ID	Inner door w/6 single slots
INCC-CABR	INCC backbox (black) with red outer door, 19" H x 19" W x 4" D (48 x 48 x 10 cm)

Optional Accessories

Part Number	Description
ANU-48	Remote LED Driver
INCC-TEL	Fire Fighter Telephone Handset (requires INCC-IDT Inner Door)
INCC-MIC	Paging Microphone Module (occupies one single slot of Inner Door)
INCC-BP	Command Center Blank Face Plate (occupies one single slot of Inner Door)

INX Intelligent Network Transponder

Part Number	Description
INX-VGX	Transponder Voice Gateway
PM-9	INX 9 ampere Power Supply
AM 50	INX 50 Watt amplifier
INX-CAB	INX 19" x 19" x 4" (48 x 48 x 10 cm) Backbox with Black Door
INX-CABR	INX 19" x 19" x 4" (48 x 48 x 10 cm) Backbox with Red Door

For additional information on the cabinets, refer to the E3 Series Cabinets data sheet (Part Number: 9020-0649).

GAMEWELL-FCI

12 Clintonville Road, Northford, CT 06472-1610 USA • Tel: (203) 484-7161 • Fax: (203) 484-7118

www.gamewell-fci.com

9020-0613 Rev. D1 page 5 of 5